

www.jee-o.com



## JEE-O original 01



Article code : geb/400-6300  
 Article code : pol/400-6380  
 Cartridge : Sedal mixer  
 Material : Stainless Steel r304  
 Connection : nylon<sup>(out)</sup>/epdm<sup>(in)</sup>  
 flexhose with brass swivel  
 Flow at water of 38°C / 100.4°F  
 12l / 3.2gal p/m at 3bar pressure  
 Dimension package :  
 L 158 x W 18 W 54 x H 16 cm  
 L 62,2 x W 7,1 W 21,3 x H 6,3"  
 Weight : 11.2 kg / 24.69 lbs  
 Package weight : 2,0kg / 4.40lbs  
 Placing on a water-tight floor  
 2 Year warranty

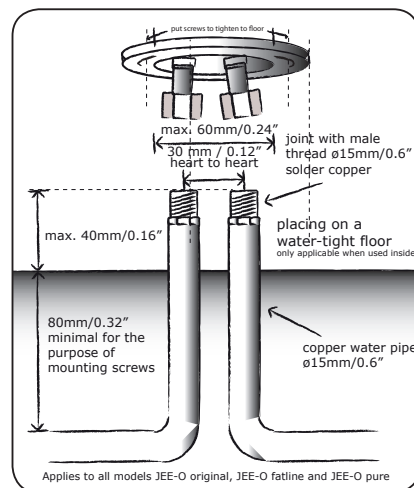

Applies to all models JEE-O original, JEE-O fatine and JEE-O pure

